

# S38

## Gate valve flange F5 S38 111 516.11 – 525.11



CE 0036

IS 9001-2008  
CERTIFIED



TÜV Rheinland  
AD 2000 Merkblatt W0  
APPROVED

# S38

## Gate valve flange F5 S38 111 516.11 – 525.11

### DIN GATE VALVES DIN PN16 - PN25 F5

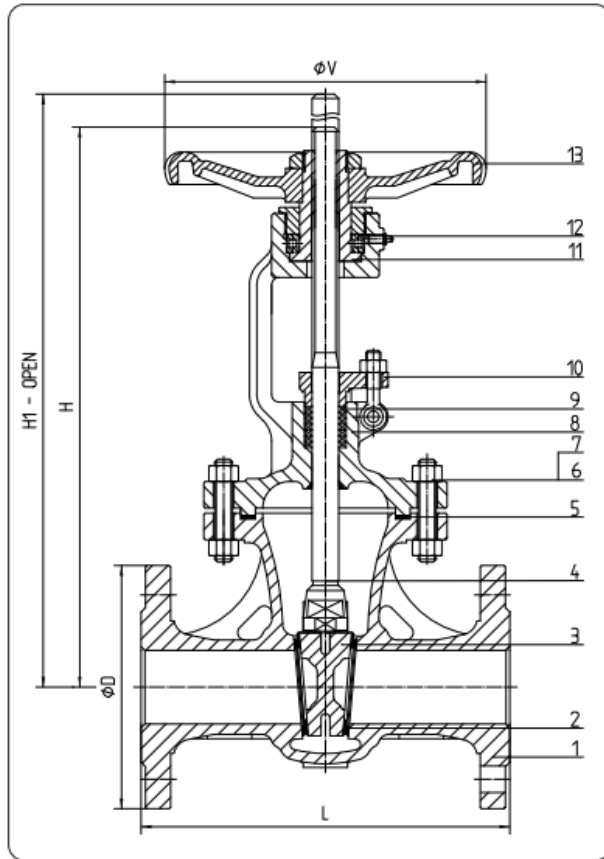

#### standard features

- **Description** OVAL BODY  
BOLTED BONNET  
OUTSIDE SCREW AND YOKE  
RISING STEM  
NON RISING HANDWHEEL  
FLEXIBLE WEDGE
- **Design** BS EN 1984
- **Face to face** BS EN 558-1 S15
- **Flanges** BS EN 1092
- **Testing** BS EN 12266 A
- **Rating** BS EN 12516
- **Marking** EN 19  
CE - PED
- **Certificates** EN 10204 – 3.1 B

PART NAME	MATERIAL		
1. Body	1.0619	1.4308	1.4408
2. Seat Surface	Overlay X20Cr13 (1)	1.4308(1)	1.4408(1)
3. Wedge Seat Surface	X20Cr13 (2)	1.4308(2)	1.4408(2)
4. Stem	X20Cr13 (3)	1.4301(3)	1.4401(3)
5. Gasket	SS304+Graphite (6)	SS304+Graphite (6)	SS316+Graphite (6)
6. Hexagon Nut	AST A194 2H	AST A194 8	ASTM A194 8
7. Bolts	AST A193 B7	ASTM A193 B8	ASTM A193 B8
8. Bonnet	1.0619	1.4308	1.4408
9. Packing	Graphite (5)	Graphite (5)	Graphite (5)
10. Gland	1.0619	1.4308	1.4308
11. Ste Nut	Cu-Alloy (4)	Cu-Alloy	Cu-Alloy
12. Bearing	Alloy Steel	Alloy Steel	Alloy Steel
13. Handwheel	C.S	C.S	C.S

- (1) On request: faced with Stellite® - Monel® - Hastelloy® - other materials  
 (2) On request: faced with Stellite® - Monel® - Hastelloy® - other materials  
 (3) On request: 17 Cr - Monel® - Hastelloy® - other materials  
 (\*) Gear operator recommended from DN 500.

- (4) On request: GGG50 - Nitronic 60  
 (5) On request: PTFE - other materials  
 (6) On request: PTFE - other materials

All data, subject to technical changes, are only for information and not for official use.

CE 0036

IS 9001-2008  
CERTIFIED



TÜV Rheinland  
AD 2000 Merkblatt W0  
APPROVED

### DIN GATE VALVES DIN PN16 - PN25 F5

**FIG.F.161 GATE VALVES DIN PN16 - Face to Face F5**

SIZE DN	50	65	80	100	125	150	200	250	300	350	400	450	500	600	700	800	900	1000	1200	1400
L RF/BW	250	270	280	300	325	350	400	450	500	550	600	650	700	800	900	1000	1100	1200	1400	1600
D	165	185	200	220	250	285	340	405	460	520	580	640	715	840	910	1025	1125	1255	1485	1685
V	200	200	225	250	280	300	400	500	500	600	600	600	600	600	1000	1200	1200	1200	1400	1400
H	400	420	500	520	610	620	780	1050	1200	1400	1580	1750	1900	2300	2600	3200	4400	4700	5200	6200
H1	470	495	580	620	720	760	980	1300	1540	1750	1980	2200	2450	3000	3500	4100	5500	5900	6600	7900

**FIG.F.162 GATE VALVES DIN PN25 - Face to Face F5**

SIZE DN	50	65	80	100	125	150	200	250	300	350	400	450	500	600	700	800	900	1000	1200	1400
L RF/BW	250	270	280	300	325	350	400	450	500	550	600	650	700	800	900	1000	1100	1200	1400	1600
D	165	185	200	235	270	300	360	425	485	555	620	670	730	845	960	1085	1185	1320	1530	1755
V	200	200	225	250	280	300	400	500	500	600	600	600	600	600	1000	1200	1200	1200	1400	1400
H	400	430	500	520	610	700	900	1050	1200	1400	1580	1750	1900	2300	2600	3200	4400	4700	5200	6200
H1	470	495	580	620	720	840	1100	1300	1540	1750	1980	2200	2450	3000	3500	4100	5500	5900	6600	7900

*features on request*

- TOP FLANGE TO ISO 5210
- GEAR OPERATOR
- CHAIN WHEEL OPERATOR
- PNEUMATIC ACTUATOR
- HYDRAULIC ACTUATOR
- ELECTRIC ACTUATOR
- POSITION INDICATOR
- LIMIT SWITCHES
- LOCKING / INTERLOCK SYSTEM
- PTFE SOFT SEATS
- STEM PROTECTION
- STEM EXTENSION
- LANTERN RING
- EXTENDED STUFFING BOX
- LIVE LOADED PACKING
- DRAIN PLUG
- BY PASS
- BW ENDS
- ANSI CONNECTIONS

All dimensions in mm (except where differently indicated)

All data, subject to technical changes, are only for information and not for official use.



IS 9001-2008  
CERTIFIED



**TÜV Rheinland**  
AD 2000 Merkblatt W0  
APPROVED